

## BEN 28 IM

- Innovative design with the tail always remaining within the width of the tracks (**Zero Tail Swing**).
- Suspension and adjustable operator's seat increases productivity by providing optimum comfort.
- Travel levers and servo-controls disabling system by armrest lifting prevents accidents due to unexpected machine movement during entry or exit from the driving place.
- Extraordinary maneuverability due to the use of pilot assisted controls (joy-sticks) to operate arms and buckets.
- Straight travel contemporary with all arms/bucket maneuvering.
- Rollers and idler wheels with rolling bushing replacing the slithering bushes for a remarkable increasing in the traction and life time performances.
- The round shape design recalls the other models of the range, thus creating a continuity of style and image.

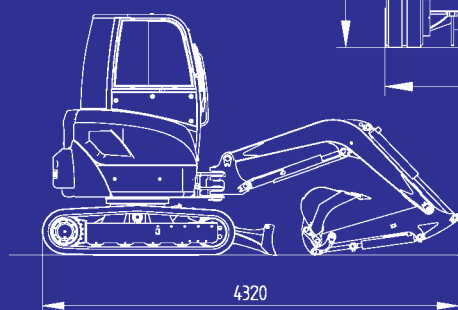

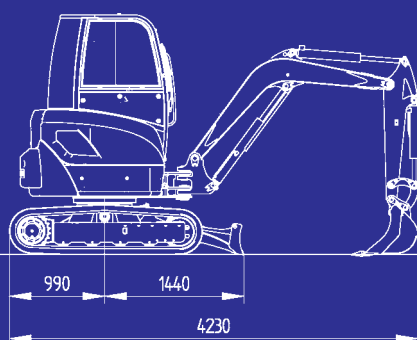
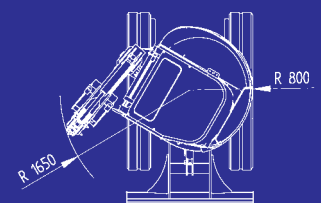
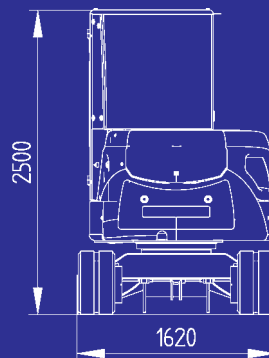
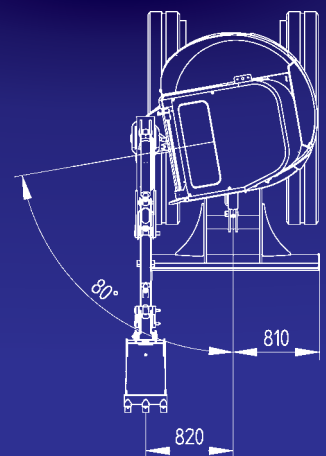
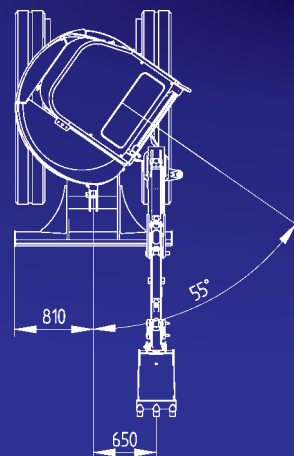
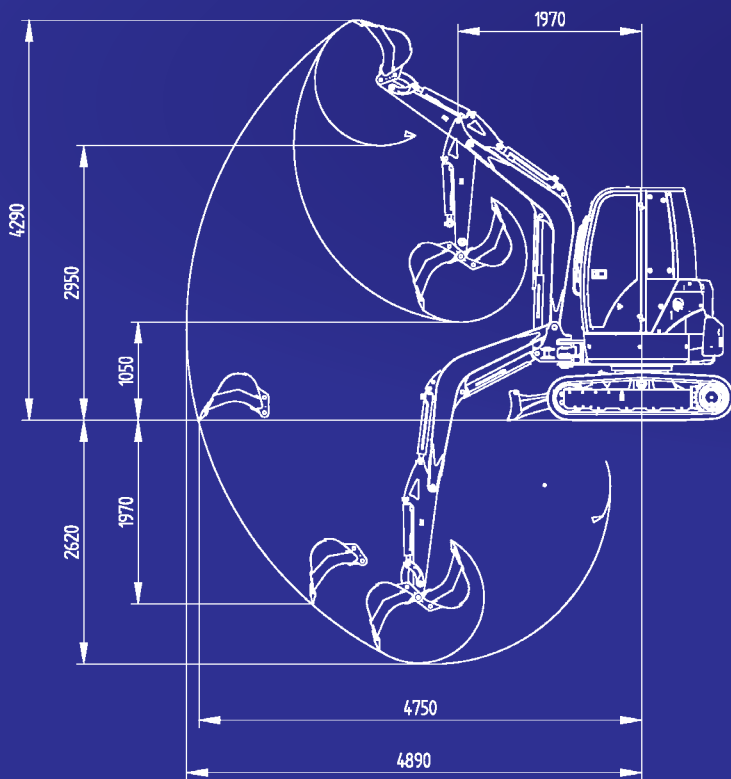

miniexcavator

# BEN 28 IM

## STANDARD EQUIPMENT

- Canopy according to TOPS-FOPS norms
- Standard bucket of mm 450 (SAE capacity lt. 64)
- 2-speeds travel electric switch
- Oil recovering system on dipstick ram
- 1200 mm. Long dipstick
- Hydraulic Power Take-Off (P.T.O.)
- Operator's and spare parts manuals.

## OPTIONAL EQUIPMENT

- Buckets of mm 250, 350, 450, 500 standard, for rocks and for Quick Hitches
- Buckets for slopes standard or swivelling
- Buckets for cleaning
- Mechanical or hydraulic Quick Hitches
- Hydraulic breaker
- Hand breaker
- Hydraulic drill
- Grass-bush cutter
- Steel tracks
- Additional ballast (202 Kg)
- 1500 mm longer arm
- Cab with heating system according to TOPS norms
- Air conditioning

## ENGINE

- Make and model Kubota D1703M
- Max power at 2800 rpm (DIN 6271) HP/Kw 35 / 25.7
- Rated horse power at 2200 rpm HP/Kw 30 / 21.8
- Cylinders N° 3
- Displacement cm<sup>3</sup> 1647
- Cooling water
- Battery N° 1 - 12 V - 65 Ah

## PERFORMANCES

- Shipping weight Kg 2680
- Operating weight Kg 2750
- Break out force daN 2620
- Digging force daN 1725
- Travel speed Km/h 2.4/4.3
- Max gradient capability more than % 100
- Specific ground pressure Kg/cm 0.28

## HYDRAULIC SYSTEM

- Hydrostatic transmission with orbital motors and planetary reduction gears with negative brakes.
- Travelling counter-balance valves
- N.2 variable displacement piston pumps + gear pump Lt/min 33 x 2 + 26
- Total delivery Lt/min 92
- Auxiliary hydraulic flow for P.T.O. Lt/min 59
- Max working pressure bar 250/200
- Slew speed rpm. 9  
(with piston motors and negative brake)
- Boom, arm, bucket and slew actuated by servo-controlled joysticks.
- Levers to control track and dozer blade; pedals to control boom swing and single and double effect P.T.O.
- Heat exchanger for oil cooling.

## UNDERCARRIAGE

- Box section steel frame
- Track type and width rubber mm 300
- Track bearing rollers N° 4+4 low/1+1 up
- Track tensioning grease
- Dozer blade mm 300 x 1600

## REFUELLING

- Fuel tank capacity lt 35
- Hydraulic oil tank capacity lt 56



**BENATI** s.r.l.  
group

Via San Pier Grisologo,26 - 40026 IMOLA (Bo)  
info@benatigroup.com - parts@benatigroup.com

www.benati.it